

Multiprocs -- Memory Organization - I

- Centralized shared-memory multiprocessor or Symmetric shared-memory multiprocessor (SMP)
- Multiple processors connected to a single centralized memory – since all processors see the same memory organization → uniform memory access (UMA)
- Shared-memory because all processors can access the entire memory address space
- Can centralized memory emerge as a bandwidth bottleneck? – not if you have large caches and employ fewer than a dozen processors

SMPs or Centralized Shared-Memory

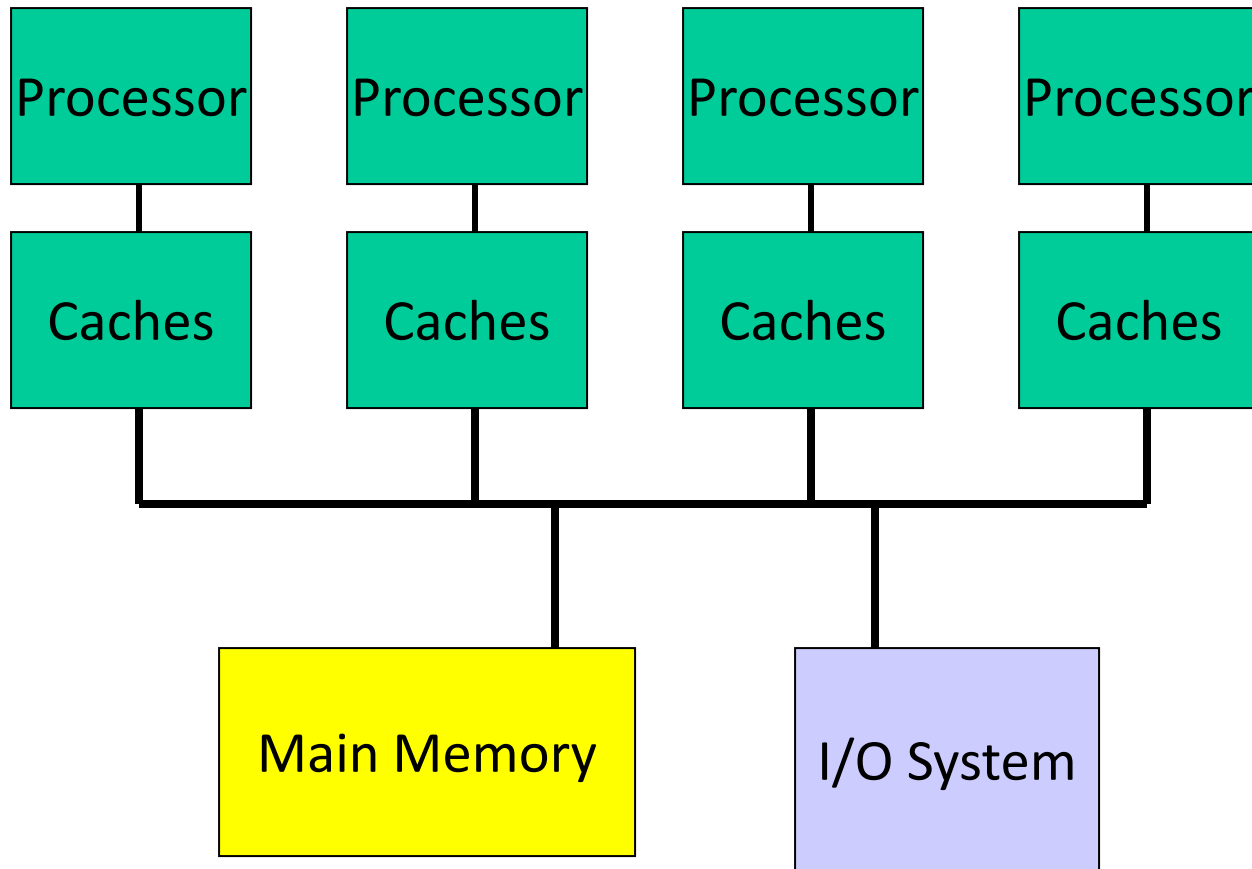

Cache Coherence

A memory system is coherent if:

- Write propagation: P1 writes to X, sufficient time elapses, P2 reads X and gets the value written by P1
- Write serialization: Two writes to the same location by two processors are seen in the same order by all processors
- The memory *consistency* model defines “time elapsed” before the effect of a processor is seen by others and the ordering with R/W to other locations (loosely speaking – more later)

SMP Example

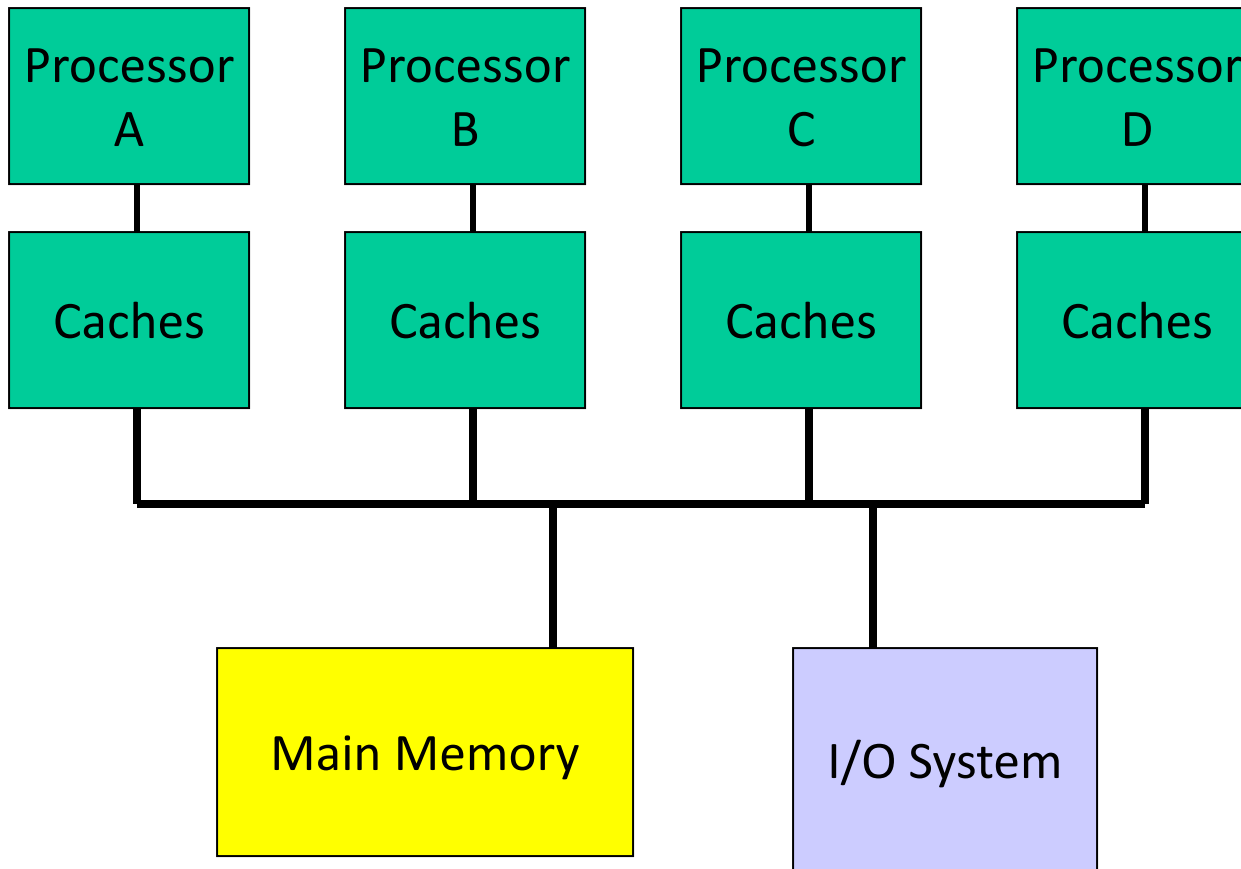

A: Rd X
B: Rd X
C: Rd X
A: Wr X
A: Wr X
C: Wr X
B: Rd X
A: Rd X
A: Rd Y
B: Wr X
B: Rd Y
B: Wr X
B: Wr Y

Example

- P1 reads X: not found in cache-1, request sent on bus, memory responds, X is placed in cache-1 in shared state
- P2 reads X: not found in cache-2, request sent on bus, everyone snoops this request, cache-1 does nothing because this is just a read request, memory responds, X is placed in cache-2 in shared state

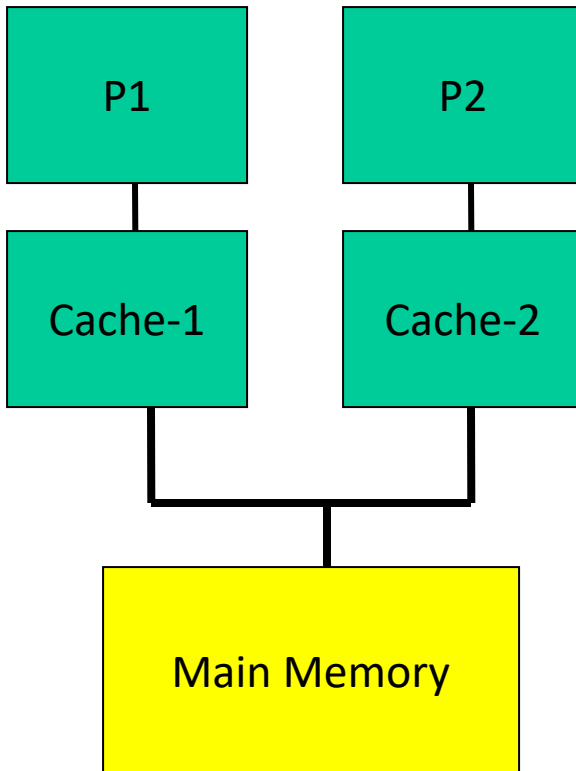

- P1 writes X: cache-1 has data in shared state (shared only provides read perms), request sent on bus, cache-2 snoops and then invalidates its copy of X, cache-1 moves its state to modified
- P2 reads X: cache-2 has data in invalid state, request sent on bus, cache-1 snoops and realizes it has the only valid copy, so it downgrades itself to shared state and responds with data, X is placed in cache-2 in shared state, memory is also updated

Example

Request	Cache Hit/Miss	Request on the bus	Who responds	State in Cache 1	State in Cache 2	State in Cache 3	State in Cache 4
				Inv	Inv	Inv	Inv
P1: Rd X	Miss	Rd X	Memory	S	Inv	Inv	Inv
P2: Rd X	Miss	Rd X	Memory	S	S	Inv	Inv
P2: Wr X	Perms Miss	Upgrade X	No response. Other caches invalidate.	Inv	M	Inv	Inv
P3: Wr X	Write Miss	Wr X	P2 responds	Inv	Inv	M	Inv
P3: Rd X	Read Hit	-	-	Inv	Inv	M	Inv
P4: Rd X	Read Miss	Rd X	P3 responds. Mem wrtbn	Inv	Inv	S	S