

Language Modeling

Mausam

(Based on slides of Michael Collins, Dan Jurafsky, Dan Klein,
Chris Manning, Luke Zettlemoyer)

Outline

- Motivation
- Task Definition
- N-Gram Probability Estimation
- Evaluation
- Hints on Smoothing for N-Gram Models
 - Simple
 - Interpolation and Back-off
 - Advanced Algorithms

The Language Modeling Problem

- **Setup:** Assume a (finite) vocabulary of words

$\mathcal{V} = \{\text{the, a, man, telescope, Beckham, two, Madrid, ...}\}$

- We can construct an (infinite) set of strings

$\mathcal{V}^\dagger = \{\text{the, a, the a, the fan, the man, the man with the telescope, ...}\}$

- **Data:** given a *training set* of example sentences $x \in \mathcal{V}^\dagger$

- **Problem:** estimate a probability distribution

$$\sum_{x \in \mathcal{V}^\dagger} p(x) = 1$$

and $p(x) \geq 0$ for all $x \in \mathcal{V}^\dagger$

$$p(\text{the}) = 10^{-12}$$

$$p(\text{a}) = 10^{-13}$$

$$p(\text{the fan}) = 10^{-12}$$

$$p(\text{the fan saw Beckham}) = 2 \times 10^{-8}$$

$$p(\text{the fan saw saw}) = 10^{-15}$$

...

The Noisy-Channel Model

- We want to predict a sentence given acoustics:

$$w^* = \arg \max_w P(w|a)$$

- The noisy channel approach:

$$w^* = \arg \max_w P(w|a)$$

$$= \arg \max_w P(a|w)P(w)/P(a)$$

$$\propto \arg \max_w P(a|w)P(w)$$

Acoustic model: Distributions
over acoustic waves given a
sentence

Language model:
Distributions over sequences
of words (sentences)

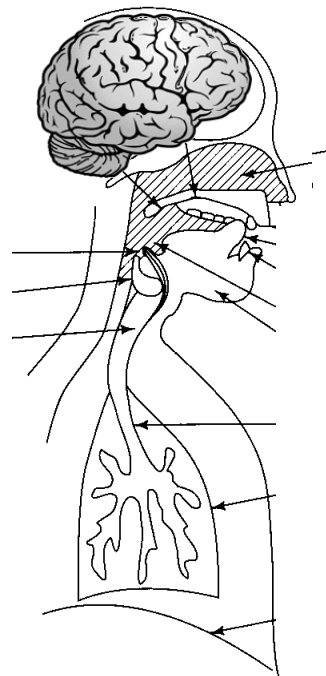

Acoustically Scored Hypotheses

the station signs are in deep in english	-14732
the stations signs are in deep in english	-14735
the station signs are in deep into english	-14739
the station 's signs are in deep in english	-14740
the station signs are in deep in the english	-14741
the station signs are indeed in english	-14757
the station 's signs are indeed in english	-14760
the station signs are indians in english	-14790
the station signs are indian in english	-14799
the stations signs are indians in english	-14807
the stations signs are indians and english	-14815

ASR System Components

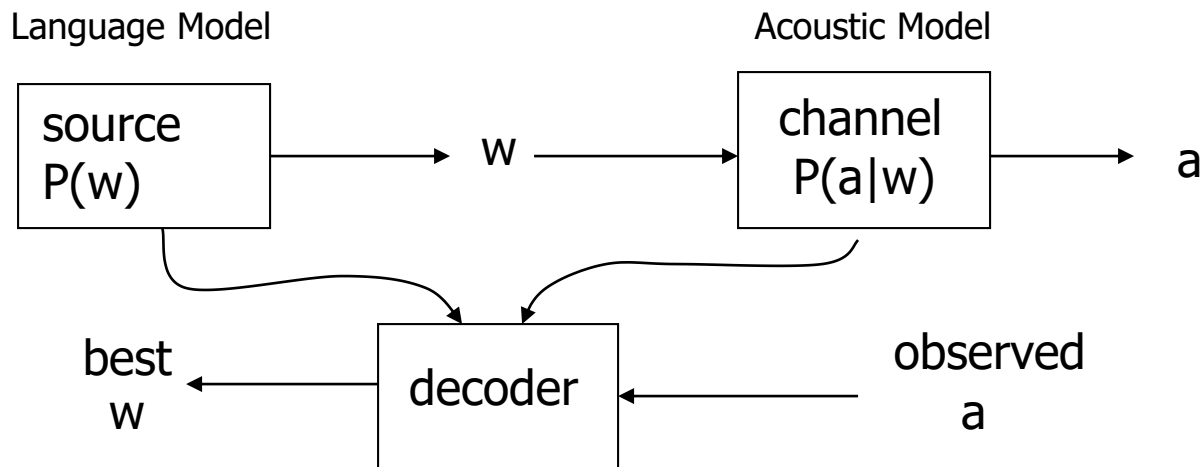

MT System Components

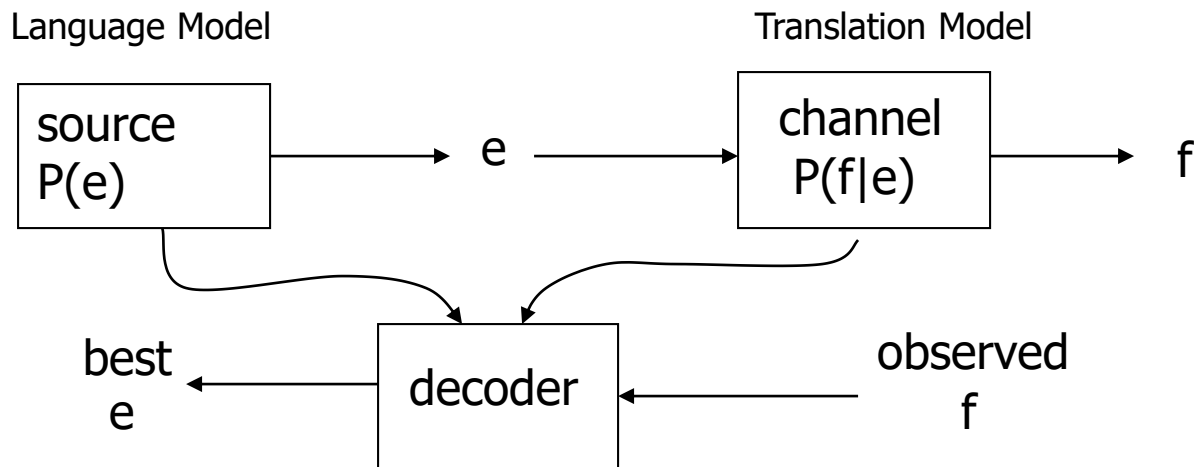

$$\operatorname{argmax}_e P(e|f) = \operatorname{argmax}_e P(f|e)P(e)$$

Probabilistic Language Models: Other Applications

- Why assign a probability to a sentence?
 - Machine Translation:
 - $P(\text{high winds tonite}) > P(\text{large winds tonite})$
 - Speech Recognition
 - $P(\text{I saw a van}) \gg P(\text{eyes awe of an})$
 - Spell Correction
 - The office is about fifteen **minuets** from my house
 - $P(\text{about fifteen minutes from}) > P(\text{about fifteen minuets from})$
 - + Summarization, question-answering, etc., etc.!!

Outline

- Motivation
- Task Definition
- N-Gram Probability Estimation
- Evaluation
- Hints on Smoothing for N-Gram Models
 - Simple
 - Interpolation and Back-off
 - Advanced Algorithms

Probabilistic Language Modeling

- Goal: compute the probability of a sentence or sequence of words:

$$P(W) = P(w_1, w_2, w_3, w_4, w_5 \dots w_n)$$

- Related task: probability of an upcoming word:

$$P(w_5 | w_1, w_2, w_3, w_4)$$

- A model that computes either of these:

$P(W)$ or $P(w_n | w_1, w_2 \dots w_{n-1})$ is called a **language model**.

How to compute $P(W)$

- How to compute this joint probability:
 - $P(\text{its, water, is, so, transparent, that})$

$P(\text{"its water is so transparent"}) =$

$$\begin{aligned} &P(\text{its}) \times P(\text{water}|\text{its}) \times P(\text{is}|\text{its water}) \\ &\quad \times P(\text{so}|\text{its water is}) \times P(\text{transparent}|\text{its water is so}) \end{aligned}$$

How to estimate these probabilities

- Could we just count and divide?

$$P(\text{the} \mid \text{its water is so transparent that}) = \frac{\textit{Count}(\text{its water is so transparent that the})}{\textit{Count}(\text{its water is so transparent that})}$$

- No! Too many possible sentences!
- We'll never see enough data for estimating these

Markov Assumption



Andrei Markov

- Simplifying assumption:

$P(\text{the } | \text{its water is so transparent that}) \gg P(\text{the } | \text{that})$

- Or maybe

$P(\text{the } | \text{its water is so transparent that}) \gg P(\text{the } | \text{transparent that})$

Markov Assumption

$$P(w_1 w_2 \cdots w_n) \approx \prod_i P(w_i | w_{i-k} \cdots w_{i-1})$$

- In other words, we approximate each component in the product

$$P(w_i | w_1 w_2 \cdots w_{i-1}) \approx P(w_i | w_{i-k} \cdots w_{i-1})$$

Simplest Case: Unigram Models

- Simplest case: unigrams

$$P(w_1 w_2 \dots w_n) \approx \prod_i P(w_i)$$

- Generative process: pick a word, pick a word, ... until you pick </s>
- Graphical model:

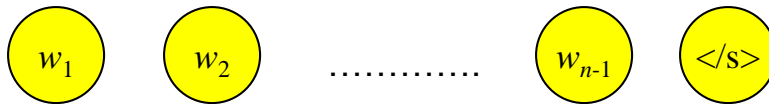

- Examples:

- fifth, an, of, futures, the, an, incorporated, a, a, the, inflation, most, dollars, quarter, in, is, mass
- thrift, did, eighty, said, hard, 'm, july, bullish
- that, or, limited, the

- Big problem with unigrams: $P(\text{the the the the}) \gg P(\text{I like ice cream})!$

Bigram Models

- Conditioned on previous single word

$$P(w_i \mid w_1 w_2 \dots w_{i-1}) \approx P(w_i \mid w_{i-1})$$

- **Generative process:** pick <s>, pick a word conditioned on previous one, repeat until to pick </s>

- **Graphical model:**

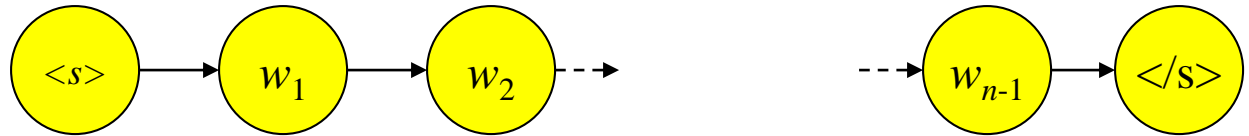

- **Examples:**

- texaco, rose, one, in, this, issue, is, pursuing, growth, in, a, boiler, house, said, mr., gurria, mexico, 's, motion, control, proposal, without, permission, from, five, hundred, fifty, five, yen
- outside, new, car, parking, lot, of, the, agreement, reached
- this, would, be, a, record, november

N-Gram Models

- We can extend to trigrams, 4-grams, 5-grams
- N-gram models are (weighted) regular languages
 - Many linguistic arguments that language isn't regular.
 - Long-distance effects: “The computer which I had just put into the machine room on the fifth floor ____.”
 - Recursive structure
 - We often get away with n-gram models
- PCFG LM (later):
 - [This, quarter, 's, surprisingly, independent, attack, paid, off, the, risk, involving, IRS, leaders, and, transportation, prices, .]
 - [It, could, be, announced, sometime, .]
 - [Mr., Toseland, believes, the, average, defense, economy, is, drafted, from, slightly, more, than, 12, stocks, .]

An example

$$P(w_i | w_{i-1}) = \frac{c(w_{i-1}, w_i)}{c(w_{i-1})}$$

<s> I am Sam </s>

<s> Sam I am </s>

<s> I do not like green eggs and ham </s>

$$P(\text{I} | \text{<s>}) = \frac{2}{3} = .67$$

$$P(\text{Sam} | \text{<s>}) = \frac{1}{3} = .33$$

$$P(\text{am} | \text{I}) = \frac{2}{3} = .67$$

$$P(\text{</s>} | \text{Sam}) = \frac{1}{2} = 0.5$$

$$P(\text{Sam} | \text{am}) = \frac{1}{2} = .5$$

$$P(\text{do} | \text{I}) = \frac{1}{3} = .33$$

More examples:

Berkeley Restaurant Project sentences

- can you tell me about any good cantonese restaurants close by
- mid priced thai food is what i'm looking for
- tell me about chez panisse
- can you give me a listing of the kinds of food that are available
- i'm looking for a good place to eat breakfast
- when is caffe venezia open during the day

Raw bigram counts

- Out of 9222 sentences

	i	want	to	eat	chinese	food	lunch	spend
i	5	827	0	9	0	0	0	2
want	2	0	608	1	6	6	5	1
to	2	0	4	686	2	0	6	211
eat	0	0	2	0	16	2	42	0
chinese	1	0	0	0	0	82	1	0
food	15	0	15	0	1	4	0	0
lunch	2	0	0	0	0	1	0	0
spend	1	0	1	0	0	0	0	0

Raw bigram probabilities

- Normalize by unigrams:

i	want	to	eat	chinese	food	lunch	spend
2533	927	2417	746	158	1093	341	278

- Result:

	i	want	to	eat	chinese	food	lunch	spend
i	0.002	0.33	0	0.0036	0	0	0	0.00079
want	0.0022	0	0.66	0.0011	0.0065	0.0065	0.0054	0.0011
to	0.00083	0	0.0017	0.28	0.00083	0	0.0025	0.087
eat	0	0	0.0027	0	0.021	0.0027	0.056	0
chinese	0.0063	0	0	0	0	0.52	0.0063	0
food	0.014	0	0.014	0	0.00092	0.0037	0	0
lunch	0.0059	0	0	0	0	0.0029	0	0
spend	0.0036	0	0.0036	0	0	0	0	0

What kinds of knowledge?

- $P(\text{english} | \text{want}) = .0011$

- $P(\text{chinese} | \text{want}) = .0065$

- $P(\text{to} | \text{want}) = .66$

- $P(\text{eat} | \text{to}) = .28$

- $P(\text{food} | \text{to}) = 0$

- $P(\text{want} | \text{spend}) = 0$

- $P(i | \langle s \rangle) = .25$

World knowledge

Grammatical knowledge

Practical Issues

- We do everything in log space
 - Avoid underflow
 - (also adding is faster than multiplying)

$$\log(p_1 \cdot p_2 \cdot p_3 \cdot p_4) = \log p_1 + \log p_2 + \log p_3 + \log p_4$$

Language Modeling Toolkits

- SRILM

- <http://www.speech.sri.com/projects/srilm/>

Google N-Gram Release, August 2006

AUG

3

All Our N-gram are Belong to You

Posted by Alex Franz and Thorsten Brants, Google Machine Translation Team

Here at Google Research we have been using word [n-gram models](#) for a variety of R&D projects,

...

That's why we decided to share this enormous dataset with everyone. We processed 1,024,908,267,229 words of running text and are publishing the counts for all 1,176,470,663 five-word sequences that appear at least 40 times. There are 13,588,391 unique words, after discarding words that appear less than 200 times.

Google N-Gram Release

- serve as the incoming 92
- serve as the incubator 99
- serve as the independent 794
- serve as the index 223
- serve as the indication 72
- serve as the indicator 120
- serve as the indicators 45
- serve as the indispensable 111
- serve as the indispensable 40
- serve as the individual 234

<http://googleresearch.blogspot.com/2006/08/all-our-n-gram-are-belong-to-you.html>

Outline

- Motivation
- Task Definition
- N-Gram Probability Estimation
- Evaluation
- Hints on Smoothing for N-Gram Models
 - Simple
 - Interpolation and Back-off
 - Advanced Algorithms

Evaluation: How good is our model?

- Does our language model prefer good sentences to bad ones?
 - Assign higher probability to “real” or “frequently observed” sentences
 - Than “ungrammatical” or “rarely observed” sentences?
- We train parameters of our model on a **training set**.
- We test the model’s performance on data we haven’t seen.
 - A **test set** is an unseen dataset that is different from our training set, totally unused.
 - An **evaluation metric** tells us how well our model does on the test set.

Extrinsic evaluation of N-gram models

- Best evaluation for comparing models A and B
 - Put each model in a task
 - spelling corrector, speech recognizer, MT system
 - Run the task, get an accuracy for A and for B
 - How many misspelled words corrected properly
 - How many words translated correctly
 - Compare accuracy for A and B

Difficulty of extrinsic (in-vivo) evaluation of N-gram models

- Extrinsic evaluation
 - Time-consuming; requires building applications, new data
- So
 - Sometimes use **intrinsic** evaluation: **perplexity**
 - Bad approximation
 - unless the test data looks **just** like the training data
 - So **generally only useful in pilot experiments**
 - But is helpful to think about.

Intuition of Perplexity

- The Shannon Game:

- How well can we predict the next word?

I always order pizza with cheese and _____

The 33rd President of the US was _____

I saw a _____

- Unigrams are terrible at this game. (Why?)

- A better model of a text

- is one which assigns a higher probability to the word that actually occurs

mushrooms 0.1

pepperoni 0.1

anchovies 0.01

....

fried rice 0.0001

....

and 1e-100

Perplexity

The best language model is one that best predicts an unseen test set

- Gives the highest $P(\text{sentence})$

Perplexity is the inverse probability of the test set, normalized by the number of words:

Chain rule:

For bigrams:

$$\begin{aligned} PP(W) &= P(w_1 w_2 \dots w_N)^{-\frac{1}{N}} \\ &= \sqrt[N]{\frac{1}{P(w_1 w_2 \dots w_N)}} \end{aligned}$$

$$PP(W) = \sqrt[N]{\prod_{i=1}^N \frac{1}{P(w_i | w_1 \dots w_{i-1})}}$$

$$PP(W) = \sqrt[N]{\prod_{i=1}^N \frac{1}{P(w_i | w_{i-1})}}$$

Minimizing perplexity is the same as maximizing probability

The Shannon Game intuition for perplexity

- From Josh Goodman
- How hard is the task of recognizing digits '0,1,2,3,4,5,6,7,8,9'
 - Perplexity 10
- How hard is recognizing (30,000) names at Microsoft.
 - Perplexity = 30,000
- If a system has to recognize
 - Operator (1 in 4)
 - Sales (1 in 4)
 - Technical Support (1 in 4)
 - 30,000 names (1 in 120,000 each)
 - Perplexity is 53
- Perplexity is weighted equivalent branching factor

Perplexity as branching factor

- Let's suppose a sentence consisting of random digits
- What is the perplexity of this sentence according to a model that assign $P=1/10$ to each digit?

$$\begin{aligned} \text{PP}(W) &= P(w_1 w_2 \dots w_N)^{-\frac{1}{N}} \\ &= \left(\frac{1}{10}\right)^{-\frac{1}{N}} \\ &= \frac{1}{10}^{-1} \\ &= 10 \end{aligned}$$

Another form of Perplexity

$$2^{-l} \text{ where } l = \frac{1}{M} \sum_{i=1}^m \log p(s_i)$$

- Lower is better!
- **Example:** $|\mathcal{V}| = N$ and $q(w|\dots) = \frac{1}{N}$
 - uniform model \rightarrow perplexity is N
- **Interpretation:** effective vocabulary size (accounting for statistical regularities)
- **Typical values for newspaper text:**
 - Uniform: 20,000; Unigram: 1000s, Bigram: 700-1000, Trigram: 100-200
- **Important note:**
 - Its easy to get bogus perplexities by having bogus probabilities that sum to more than one over their event spaces. Be careful!

Lower perplexity = better model

- Training 38 million words, test 1.5 million words, WSJ

N-gram Order	Unigram	Bigram	Trigram
Perplexity	962	170	109

Outline

- Motivation
- Task Definition
- Probability Estimation
- Evaluation
- Smoothing
 - Simple
 - Interpolation and Back-off
 - Advanced Algorithms

The Shannon Visualization Method

- Choose a random bigram
(`<s>`, `w`) according to its probability
- Now choose a random bigram
(`w`, `x`) according to its probability
- And so on until we choose `</s>`
- Then string the words together

```
<s> I
    I want
      want to
        to eat
          eat Chinese
            Chinese food
              food </s>

I want to eat Chinese food
```

Approximating Shakespeare

Unigram

To him swallowed confess hear both. Which. Of save on trail for are ay device and rote life have
Every enter now severally so, let
Hill he late speaks; or! a more to leg less first you enter
Are where exeunt and sighs have rise excellency took of.. Sleep knave we. near; vile like

Bigram

What means, sir. I confess she? then all sorts, he is trim, captain.
Why dost stand forth thy canopy, forsooth; he is this palpable hit the King Henry. Live king. Follow.
What we, hath got so she that I rest and sent to scold and nature bankrupt, nor the first gentleman?

Trigram

Sweet prince, Falstaff shall die. Harry of Monmouth's grave.
This shall forbid it should be branded, if renown made it empty.
Indeed the duke; and had a very good friend.
Fly, and will rid me these news of price. Therefore the sadness of parting, as they say, 'tis done.

Quadrigram

King Henry. What! I will go seek the traitor Gloucester. Exeunt some of the watch. A great banquet serv'd in;
Will you not tell me who I am?
It cannot be but so.
Indeed the short and the long. Marry, 'tis a noble Lepidus.

Shakespeare as corpus

- $N=884,647$ tokens, $V=29,066$
- Shakespeare produced 300,000 bigram types out of $V^2= 844$ million possible bigrams.
 - So 99.96% of the possible bigrams were never seen (have zero entries in the table)
- Quadrigrams worse: What's coming out looks like Shakespeare because it *is* Shakespeare

The perils of overfitting

- N-grams only work well for word prediction if the test corpus looks like the training corpus
 - In real life, it often doesn't
 - We need to train robust models that generalize!
 - One kind of generalization: Zeros!
 - Things that don't ever occur in the training set
 - But occur in the test set

Unknown words: Open vs closed vocabulary tasks

- If we know all the words in advanced
 - Vocabulary V is fixed
 - Closed vocabulary task
- Often we don't know this
 - **Out Of Vocabulary** = OOV words
 - Open vocabulary task
- Instead: create an unknown word token <UNK>
 - Training of <UNK> probabilities
 - Create a fixed lexicon L of size V
 - At text normalization phase, any training word not in L changed to <UNK>
 - Now we train its probabilities like a normal word
 - At decoding time
 - If text input: Use UNK probabilities for any word not in training

Zeros

- Training set:
 - ... denied the allegations
 - ... denied the reports
 - ... denied the claims
 - ... denied the request
- Test set
 - ... denied the offer
 - ... denied the loan

$$P(\text{"offer"} \mid \text{denied the}) = 0$$

Zero probability bigrams

- Bigrams with zero probability
 - mean that we will assign 0 probability to the test set!
- And hence we cannot compute perplexity (can't divide by 0)!

The intuition of smoothing

- When we have sparse statistics:

$P(w \mid \text{denied the})$
3 allegations
2 reports
1 claims
1 request
7 total

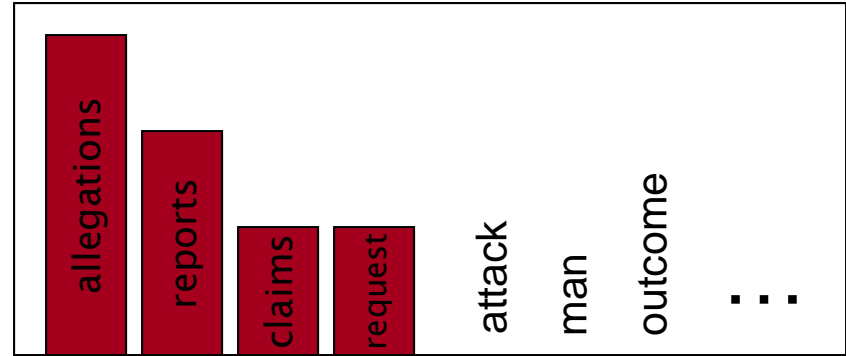

- Steal probability mass to generalize better

$P(w \mid \text{denied the})$
2.5 allegations
1.5 reports
0.5 claims
0.5 request
2 other
7 total

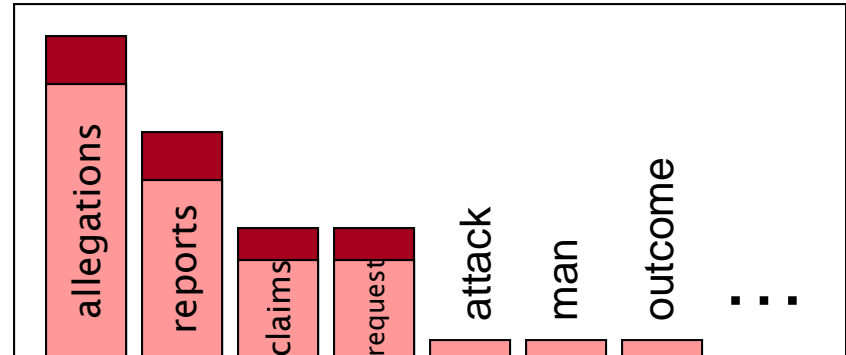

Add-one estimation

- Also called Laplace smoothing
- Pretend we saw each word one more time than we did
- Just add one to all the counts!

- MLE estimate:

$$P_{MLE}(w_i | w_{i-1}) = \frac{c(w_{i-1}, w_i)}{c(w_{i-1})}$$

- Add-1 estimate:

$$P_{Add-1}(w_i | w_{i-1}) = \frac{c(w_{i-1}, w_i) + 1}{c(w_{i-1}) + V}$$

Berkeley Restaurant Corpus: Laplace smoothed bigram counts

	i	want	to	eat	chinese	food	lunch	spend
i	6	828	1	10	1	1	1	3
want	3	1	609	2	7	7	6	2
to	3	1	5	687	3	1	7	212
eat	1	1	3	1	17	3	43	1
chinese	2	1	1	1	1	83	2	1
food	16	1	16	1	2	5	1	1
lunch	3	1	1	1	1	2	1	1
spend	2	1	2	1	1	1	1	1

Laplace-smoothed bigrams

$$P^*(w_n|w_{n-1}) = \frac{C(w_{n-1}w_n) + 1}{C(w_{n-1}) + V}$$

	i	want	to	eat	chinese	food	lunch	spend
i	0.0015	0.21	0.00025	0.0025	0.00025	0.00025	0.00025	0.00075
want	0.0013	0.00042	0.26	0.00084	0.0029	0.0029	0.0025	0.00084
to	0.00078	0.00026	0.0013	0.18	0.00078	0.00026	0.0018	0.055
eat	0.00046	0.00046	0.0014	0.00046	0.0078	0.0014	0.02	0.00046
chinese	0.0012	0.00062	0.00062	0.00062	0.00062	0.052	0.0012	0.00062
food	0.0063	0.00039	0.0063	0.00039	0.00079	0.002	0.00039	0.00039
lunch	0.0017	0.00056	0.00056	0.00056	0.00056	0.0011	0.00056	0.00056
spend	0.0012	0.00058	0.0012	0.00058	0.00058	0.00058	0.00058	0.00058

Reconstituted counts

$$c^*(w_{n-1}w_n) = \frac{[C(w_{n-1}w_n) + 1] \times C(w_{n-1})}{C(w_{n-1}) + V}$$

	i	want	to	eat	chinese	food	lunch	spend
i	3.8	527	0.64	6.4	0.64	0.64	0.64	1.9
want	1.2	0.39	238	0.78	2.7	2.7	2.3	0.78
to	1.9	0.63	3.1	430	1.9	0.63	4.4	133
eat	0.34	0.34	1	0.34	5.8	1	15	0.34
chinese	0.2	0.098	0.098	0.098	0.098	8.2	0.2	0.098
food	6.9	0.43	6.9	0.43	0.86	2.2	0.43	0.43
lunch	0.57	0.19	0.19	0.19	0.19	0.38	0.19	0.19
spend	0.32	0.16	0.32	0.16	0.16	0.16	0.16	0.16

Compare with raw bigram counts

	i	want	to	eat	chinese	food	lunch	spend
i	5	827	0	9	0	0	0	2
want	2	0	608	1	6	6	5	1
to	2	0	4	686	2	0	6	211
eat	0	0	2	0	16	2	42	0
chinese	1	0	0	0	0	82	1	0
food	15	0	15	0	1	4	0	0
lunch	2	0	0	0	0	1	0	0
spend	1	0	1	0	0	0	0	0

	i	want	to	eat	chinese	food	lunch	spend
i	3.8	527	0.64	6.4	0.64	0.64	0.64	1.9
want	1.2	0.39	238	0.78	2.7	2.7	2.3	0.78
to	1.9	0.63	3.1	430	1.9	0.63	4.4	133
eat	0.34	0.34	1	0.34	5.8	1	15	0.34
chinese	0.2	0.098	0.098	0.098	0.098	8.2	0.2	0.098
food	6.9	0.43	6.9	0.43	0.86	2.2	0.43	0.43
lunch	0.57	0.19	0.19	0.19	0.19	0.38	0.19	0.19
spend	0.32	0.16	0.32	0.16	0.16	0.16	0.16	0.16

More general formulations: Add-k

$$P_{Add-k}(w_i | w_{i-1}) = \frac{c(w_{i-1}, w_i) + k}{c(w_{i-1}) + kV}$$

$$P_{Add-k}(w_i | w_{i-1}) = \frac{c(w_{i-1}, w_i) + m\left(\frac{1}{V}\right)}{c(w_{i-1}) + m}$$

What counts do we want?

Count c	New count c^*
0	.0000270
1	0.446
2	1.26
3	2.24
4	3.24
5	4.22
6	5.19
7	6.21
8	7.24
9	8.25

Absolute Discounting

- Just subtract 0.75 (or some d)!

$$P_{\text{AbsoluteDiscounting}}(w_i | w_{i-1}) = \frac{c(w_{i-1}, w_i) - d}{c(w_{i-1})}$$

discounted bigram ↙

(Maybe keeping a couple extra values of d for counts 1 and 2)

- Problem: all unknown bigrams are equally likely!

Outline

- Motivation
- Task Definition
- Probability Estimation
- Evaluation
- Smoothing
 - Simple
 - Interpolation and Back-off
 - Advanced Algorithms

Backoff and Interpolation

- Sometimes it helps to use **less** context
 - Condition on less context for contexts you haven't learned much about
- **Backoff:**
 - use trigram if you have good evidence,
 - otherwise bigram, otherwise unigram
- **Interpolation:**
 - mix unigram, bigram, trigram
- Interpolation often works better

Backoff

- Define the words into seen and unseen

$$A(v) = \{w : c(v, w) > 0\} \quad B(v) = \{w : c(v, w) = 0\}$$

- Backoff

$$P_{\text{BO}}(w_i | w_{i-1}) = \begin{cases} \frac{c(w_{i-1}, w_i)}{c(w_{i-1})} & w_i \in A(w_{i-1}) \\ P(w_i) & w_i \in B(w_{i-1}) \end{cases}$$

- Problem?

- Not a probability distribution

Katz Backoff

$$P_{\text{ML}}(w_i | w_{i-1}) = \frac{c(w_{i-1}, w_i)}{c(w_{i-1})}$$

$$P^*(w_i | w_{i-1}) < P_{\text{ML}}(w_i | w_{i-1})$$

- Define the words into seen and unseen

$$A(v) = \{w : c(v, w) > k\}$$

$$B(v) = \{w : c(v, w) \leq k\}$$

- Backoff

$$P_{\text{BO}}(w_i | w_{i-1}) = \begin{cases} P^*(w_i | w_{i-1}) & w_i \in A(w_{i-1}) \\ \alpha(w_{i-1})P(w_i) & w_i \in B(w_{i-1}) \end{cases}$$

$$\alpha(w_{i-1}) = \frac{1 - \sum_{w \in A(w_{i-1})} P^*(w | w_{i-1})}{\sum_{w \in B(w_{i-1})} P(w)}$$

Linear Interpolation

- Simple interpolation

$$\begin{aligned}\hat{P}(w_n|w_{n-1}w_{n-2}) &= \lambda_1 P(w_n|w_{n-1}w_{n-2}) \\ &+ \lambda_2 P(w_n|w_{n-1}) \\ &+ \lambda_3 P(w_n)\end{aligned}$$

$$\sum_i \lambda_i = 1$$

- Lambdas conditional on context:

$$\begin{aligned}\hat{P}(w_n|w_{n-2}w_{n-1}) &= \lambda_1(w_{n-2}^{n-1})P(w_n|w_{n-2}w_{n-1}) \\ &+ \lambda_2(w_{n-2}^{n-1})P(w_n|w_{n-1}) \\ &+ \lambda_3(w_{n-2}^{n-1})P(w_n)\end{aligned}$$

How to set the lambdas?

- Use a **held-out** corpus

Training Data

Held-Out
Data

Test
Data

- Choose λ s to maximize the probability of held-out data:
 - Fix the N-gram probabilities (on the training data)
 - Then search for λ s that give largest probability to held-out set:

$$\log P(w_1 \dots w_n | M(l_1 \dots l_k)) = \sum_i \log P_{M(l_1 \dots l_k)}(w_i | w_{i-1})$$

Absolute Discounting Interpolation

$$P_{\text{AbsoluteDiscounting}}(w_i | w_{i-1}) = \frac{\overset{\text{discounted bigram}}{c(w_{i-1}, w_i) - d}}{c(w_{i-1})} + \overset{\text{Interpolation weight}}{\lambda(w_{i-1})} \overset{\text{unigram}}{P(w_i)}$$

- But should we really just use the regular unigram $P(w)$?

Kneser-Ney Smoothing I

- Better estimate for probabilities of lower-order unigrams!
 - Shannon game: *I can't see without my reading* Francisco ?
 - “Francisco” is more common than “glasses”
 - ... but “Francisco” always follows “San”
- The unigram is useful exactly when we haven't seen this bigram!
- Instead of $P(w)$: “How likely is w ”
- $P_{\text{continuation}}(w)$: “How likely is w to appear as a novel continuation?”
 - For each word, count the number of bigram types it completes
 - Every bigram type was a novel continuation the first time it was seen

$$P_{\text{CONTINUATION}}(w) \propto |\{w_{i-1} : c(w_{i-1}, w) > 0\}|$$

Kneser-Ney Smoothing II

- How many times does w appear as a novel continuation:

$$P_{CONTINUATION}(w) \propto |\{w_{i-1} : c(w_{i-1}, w) > 0\}|$$

- Normalized by the total number of word bigram types

$$|\{(w_{j-1}, w_j) : c(w_{j-1}, w_j) > 0\}|$$

$$P_{CONTINUATION}(w) = \frac{|\{w_{i-1} : c(w_{i-1}, w) > 0\}|}{|\{(w_{j-1}, w_j) : c(w_{j-1}, w_j) > 0\}|}$$

Kneser-Ney Smoothing III

- Alternative metaphor: The number of # of word types seen to precede w

$$|\{w_{i-1} : c(w_{i-1}, w) > 0\}|$$

- normalized by the # of words preceding all words:

$$P_{CONTINUATION}(w) = \frac{|\{w_{i-1} : c(w_{i-1}, w) > 0\}|}{\sum_{w'} |\{w'_{i-1} : c(w'_{i-1}, w') > 0\}|}$$

- A frequent word (Francisco) occurring in only one context (San) will have a low continuation probability

Kneser-Ney Smoothing IV

$$P_{KN}(w_i | w_{i-1}) = \frac{\max(c(w_{i-1}, w_i) - d, 0)}{c(w_{i-1})} + l(w_{i-1})P_{CONTINUATION}(w_i)$$

λ is a normalizing constant; the probability mass we've discounted

$$l(w_{i-1}) = \frac{d}{c(w_{i-1})} \left| \{w : c(w_{i-1}, w) > 0\} \right|$$

the normalized discount

The number of word types that can follow w_{i-1}
= # of word types we discounted
= # of times we applied normalized discount

Kneser-Ney Smoothing: Recursive formulation

$$P_{KN}(w_i | w_{i-n+1}^{i-1}) = \frac{\max(c_{KN}(w_{i-n+1}^i) - d, 0)}{c_{KN}(w_{i-n+1}^{i-1})} + I(w_{i-n+1}^{i-1})P_{KN}(w_i | w_{i-n+2}^{i-1})$$

where

$$P_{KN}(w_i | w_{i-1}) = \frac{\max(c(w_{i-1}, w_i) - d, 0)}{c(w_{i-1})} + I(w_{i-1})P_{CONTINUATION}(w_i)$$

What Actually Works?

- **Trigrams and beyond:**
 - Unigrams, bigrams generally useless
 - Trigrams much better (when there's enough data)
 - 4-, 5-grams really useful in MT, but not so much for speech
- **Discounting**
 - Absolute discounting, Good-Turing, held-out estimation, Witten-Bell, etc...
- See [Chen+Goodman] reading for tons of graphs...

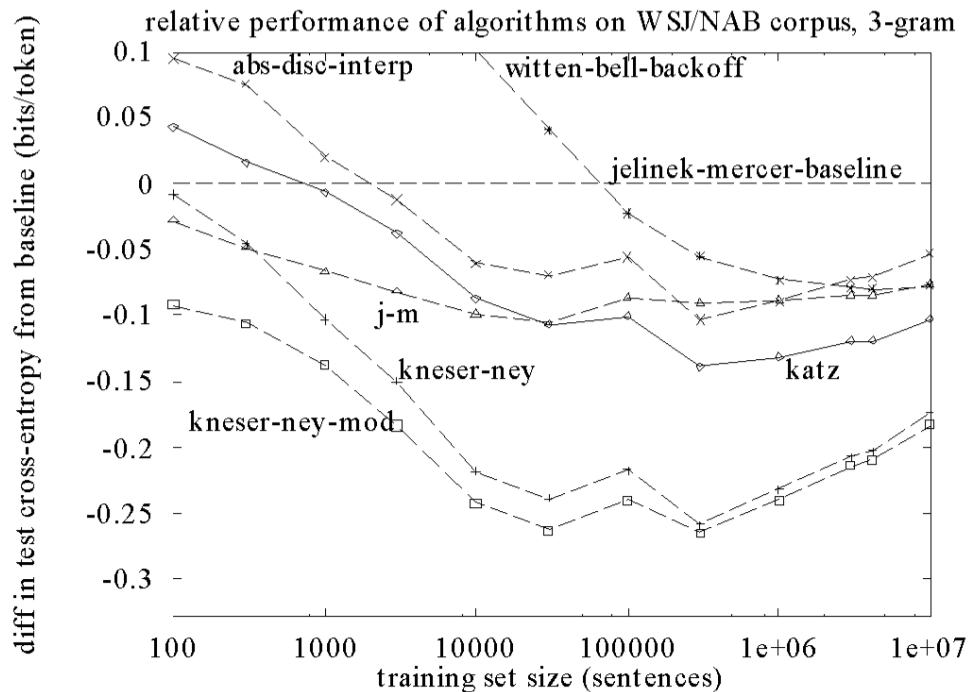

[Graphs from
Joshua Goodman]

Data vs. Method?

- Having more data is better...
- ... but so is using a better estimator
- Another issue: $N > 3$ has huge costs in speech recognizers

